

Current clamps 1000A for analysers and testers

Calmet CT1000AC.B	
•	Wide range of current measurement: 0.3A to 1000A
•	50mm maximum conductor size
•	Easy to assembly in hard access places
•	Exchangeability of clamps between devices with keeping accuracy
•	Works with Calmet TE30Lite, Calmet TE30 and Calmet TS33 testers



Current clamps CT1000AC.B allow for easy current measurement on cables and bars in electric installation. Due to narrow jaws and large hole diameter, it is easy to assembly them in hard access places. Maximum diameter of cable, on which we can close the sensor is about 50mm.

Technical specification

Parameter	Value
Range of current	0.3A – 1000A AC
Output voltage	1mV / 1A
Minimum load impedance	$\geq 1M\Omega$
Accuracy	0.2% m.v. in range 10 to 1000A 0.2% r.v. in range 0.3 to <u>10A</u>
Frequency range	30Hz to 10kHz
Maximum voltage of cable / bar to earth	600V AC RMS
Length of connecting cable	2.10m
Temperature range operation / storage	0°C to +50°C/-10°C to 60°C
Dimensions of single clamp	102,9 x 219,6 x 28 mm
Weight	approx. 1.8kg
Safety	600V RMS, Cat. III, Pollution degree 2
Safety standards	EN 61010-1, -2, -031

m.v. – measured value; r.v. – range value (underlined)

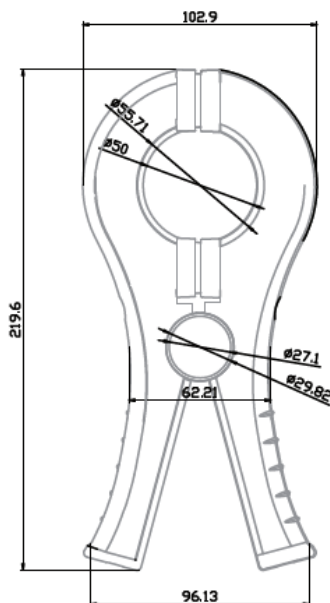
Current clamp dimensions

Calmet sp. z o.o.
 Kukulcza 18 Street, 65-472 Zielona Gora, Poland
 Tel. +48 68 324 04 56 Fax +48 68 324 04 57
 E-mail: mail@calmet.com.pl Internet: http://www.calmet.com.pl

Warning!

- **current clamps can be only used by qualified personnel;**
- **protect current clamps against water and humidity;**
- **always connect current clamp to tester before installing it on cable;**
- **keep clean current jaws to avoid additional errors**
- **open the jaws by pressing the lever, place clamp on the conductor and close jaws precisely;**
- **never use current clamp for measurements on cables with voltage greater than 600V.**

Measurement Procedure

- 1- Connect the output connector to the analyser or tester;
- 2- Open the jaws by pressing the lever in, then clamp the conductor. Make sure that only one conductor is in the jaws;
- 3- Close the jaws and make sure that the tip of jaws are fully closed;