

## Single Position Meter Test Bench for smart meters

### Calmet TS33 option TB1

- New generation of the fully automated Smart Meter Test Bench
- Accuracy class 0.02%, 0.04% or 0.1% with internal – built in reference meter!
- Extremely high accuracy class with external reference meter
- Automatic Test Procedures and Test Reports
- Testing meters with “closed link” - permanent connection between U&I
- Programmed form (harmonics) & special shapes of currents and voltages
- Three-phase current and voltage source in range 0.001A...120A (60VA) and 20V...600V (30VA) per channel
- Signal generation without additional auxiliary amplifiers
- Compact design, size and light weight
- AC single phase power supply operation only (<500VA)

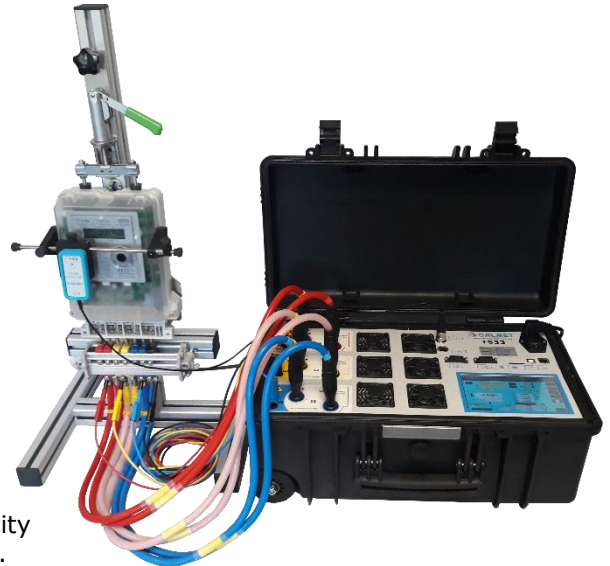

Calmet TS33 option TB1 Single Position Meter Test Bench is used for calibration and testing one single and three phase electromechanical and electronic active and reactive electricity meter with accuracy referenced to an internal reference meter.

Calmet TS33 option TB1 economic Test Bench employs modern precision power source with the internal reference (without need to use any additional external reference energy meter). By this conception may be achieved customer orientated solution characterised by extremely compact size, light weight, high metrological properties at reasonable price. You buy exactly what you need without additional table and mechanical design. In case of higher-accuracy application requirement, it is possible to upgrade the existing Calmet TS33 option TB1 Test Bench by adding an external reference meter.

The Calmet TS33 option TB1 Test Bench comprises:

- three phase power source with internal reference accuracy 0.02, 0.04 or 0.1. Power source generates voltage up to 600V and current up to 120A with programmable shapes, frequency in 45...65Hz range and phase shifts in -180°... 0°...+180° range,
- single position testing stand with photo scanning head, quick connector and cables,
- optional PC laptop with installed TS PC Soft for controlling of testing process in case the user doesn't want to use built in 7" colour, touch screen.

The Calmet TS33 option TB1 Test Bench performs the following automatic tests of electricity meters:

- measure the basic error characteristics and repeatability for power and energy: P, P+, P-, PH1, PH1+, PH1-, Q, Q+, Q-, QH1, QH1+, QH1-, S, S+, S-, SH1, SH1+, SH1-,
- checking the counter (register) error, starting current and no-load run,
- measure the influence of frequency, voltage, self-heating, reversed phase sequence, distortion and special shapes of currents and voltages.

### Configuration of the Calmet TS33 option TB1

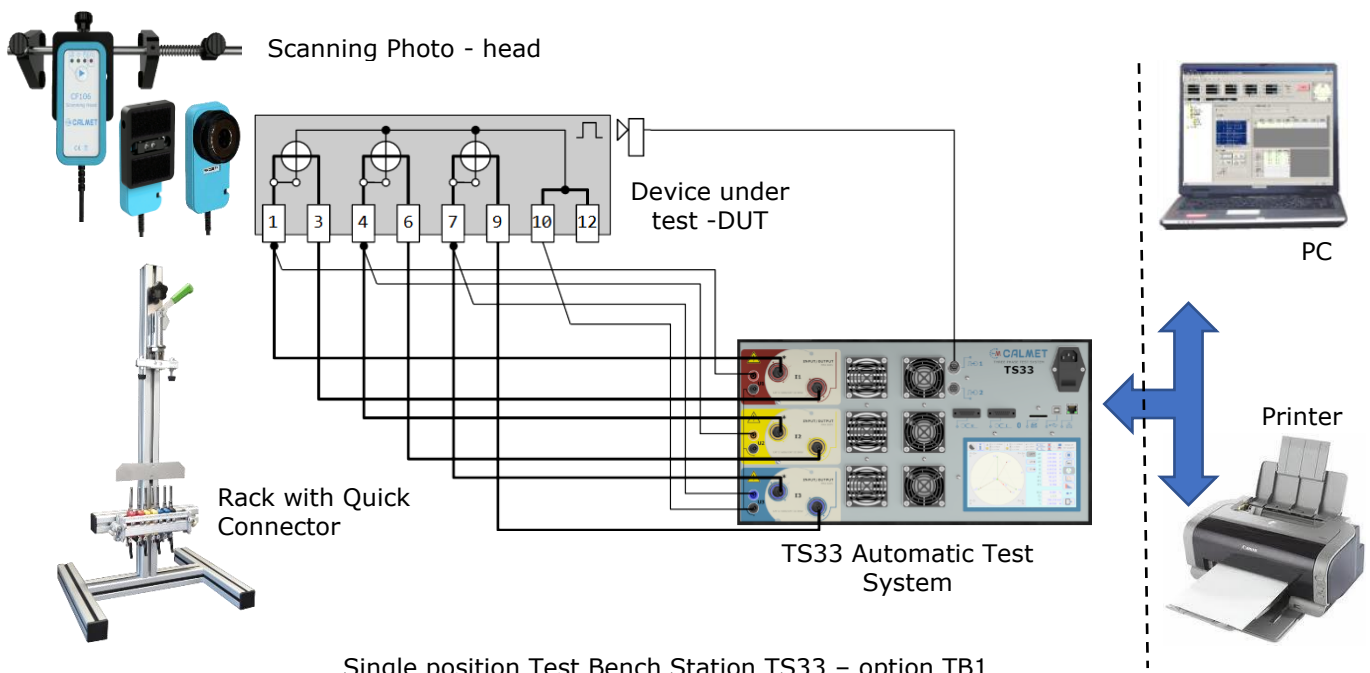

Single position Test Bench Station TS33 – option TB1

Internal Reference Meter Specifications					
Parameter	Range	Accuracy <sup>1)2)3)4)</sup>			
		class 0.02	class 0.04	class 0.1	
Voltage	0.05...600V	±0.02% <sup>5)</sup>	±0.04% <sup>5)</sup>	±0.1% <sup>5)</sup>	
Current	0.01...120A	±0.02%	±0.04%	±0.1%	
	0.001... <u>0.01A</u>	±0.02%*	±0.04%*	±0.1%*	
Power and energy	0.01...120A / 10...600V	±0.02%	±0.04%	±0.1%	
	0.001... <u>0.01A</u> / 10...600V	±0.02%*	±0.04%*	±0.1%*	
Frequency	40...70Hz		±0.003Hz		
Phase shift	-180...+180°	±0.01° <sup>5)6)</sup>	±0.02° <sup>5)6)</sup>	±0.04° <sup>5)6)</sup>	
Power factor cosφ and sinφ	0...±1		±0.001 <sup>5)6)</sup>		
Temperature coefficient	0.001% per 1°C in range -10...+50°C				
Time stability for Energy	Short term [1h] = 0.01%, long term [1 year] = 0.03%				
Power short term [1h] stability		±0.005%	±0.010%	±0.020%	
Power long term [1 year] stability		±0.010%	±0.025%	±0.050%	
Power temperature coefficient per 1°C		±0.001%	±0.002%	±0.005%	
<sup>1)</sup> % - related to the measuring value, %* - related to the measuring range final value (is underlined) <sup>2)</sup> absolute extended uncertainty under confidence level of 95% covers reference uncertainty of standards, stability in 12 months, influence quantities (ambient temperature +20...+26°C, humidity and power supply voltage 90...264V, frequency 47...63Hz) <sup>4)</sup> power and energy errors related to apparent power <sup>5)</sup> in voltage range 10...600V <sup>6)</sup> in current range 0.01...120A					
Reference Meter Specifications for the power quality parameters					
Parameter	Range		Accuracy <sup>1)</sup>		
Harmonics in voltages, currents, P and Q powers	amplitude	0...100% of input	1 <sup>st</sup> ...63 <sup>rd</sup>	±0.1% <sup>2)</sup>	
	phase	-180...+180°		±0.5° <sup>3)</sup>	
Total harmonic distortion THD in voltages and currents	0...100% of input		1 <sup>st</sup> ...63 <sup>rd</sup>	±0.1% <sup>2)</sup>	
Total interharmonic distortion TID in voltages and currents	0...15% of input		40...3200Hz	±0.2% <sup>4)</sup>	
Signal voltage <sup>5)</sup>	0...15% of input		40...3200Hz	±5%	
Voltage asymmetry	0...100%			±2%	
<sup>1)</sup> absolute extended uncertainty under confidence level of 95% covers reference uncertainty of standards, stability in 12 months, influence quantities (ambient temperature +20...+26°C, humidity and power supply voltage 90...264V, frequency 47...63Hz) <sup>2)</sup> of input for 80-140Hz frequency range of harmonics with linear rise to 0.4% of input for 3200Hz <sup>3)</sup> for 80-140Hz frequency range of harmonics with linear rise to 8° for 3200Hz <sup>4)</sup> of input for 80-140Hz frequency range of interharmonics with linear rise to 5% of input for 3200Hz <sup>5)</sup> the highest non-harmonic amplitude and frequency					
Three Phase Power Source Specification for the sinusoidal signals					
Parameter	Range	Settings span	Resolution	Accuracy <sup>1)2)3)4)</sup>	Maximum load
Voltage U	150V	20...150V	0.001V	See the specification of reference meter	200mA@150V
	300V	150...300V	0.01V		100mA@300V
	600V	300...600V	0.01V		50mA@600V
Voltage short term [10min] stability				±0.01%	
Voltage short term [1h] stability				±0.03%	
Voltage distortion factor				< 0.5%	
Current I	0.12A	0.02...0.12A 0.001... <u>0.02</u>	0.00001A	See the specification of reference meter	4V@0.01A 3V@0.12A
	1A	0.12A...1A	0.00001A		16V@0.12A 12V@1A
	12A	1...12A	0.0001A		6.0V@1A 5.0V@12A
	120A	12...120A	0.001A		0.70V@12A 0.65V@60A 0.50V@120A
Current short term [10min] stability				±0.01% <sup>3)</sup>	
Current short term [1h] stability				±0.03% <sup>3)</sup>	
Current distortion factor				< 0.5% <sup>5)</sup>	
Frequency f	45...65Hz		0.001Hz	±0.003Hz	
Phase shift φ	-180...+180°		0.001°	±0.10°	
Phase shift short term [10min] stability				±0.05°	
<sup>1)</sup> absolute extended uncertainty under confidence level of 95% covers reference uncertainty of standards, stability in 12 months, influence quantities (ambient temperature +20...+26°C, humidity and power supply voltage 90...264V, frequency 47...63Hz) <sup>2)</sup> % - related to the setting value, %* - related to the setting span final value (is underlined) <sup>3)</sup> in current range 0.02...120A <sup>4)</sup> for voltage and current source mode only					
Three Phase Power Source Specification for the nonsinusoidal signals					
Parameter	Settings span		Resolution	Conditions	
Harmonics	amplitude	0...50% output value <sup>1)</sup>		0.1%	up to 63 <sup>rd</sup> or 3200Hz
	phase	-180...+180°		0.1°	
<sup>1)</sup> 50% of output value for frequency range of harmonics to 500Hz with linear decrease to 10% of output value for 3200Hz					
Specifications for impulse input/output					
Parameter	Voltage range	Frequency range	Resolution	Accuracy	
Impulse Input for counting pulses (two inputs)	0...2V/4...30V	0.0001Hz...210kHz	0.0001%	0.001%@t≥1s	
Impulse Output for Calmet TS33 testing	open collector 28V/100mA	0.0001Hz...210kHz	0.0001%	0.001%	

General parameters	
Weight TS33 / TS33 + ER10H.3 + EA30	22kg / 31kg
Dimensions: width x height x depth of TS33	(550x345x200) mm
Power supply	90...264V / 47...63Hz / 500VA
Safety: Isolation protection and Measurement Category	IEC 61140 and 300V CAT III / 600V CAT II
Degree of protection	IP-20
Operation / storage temperature	-10...+40°C / -20...+60°C
Operation / storage relative humidity	<90% @ +0...+30°C and <75% @ +30...+50°C / <95% @ 0...+50°C

**The TS33 option TB1 – data management, on site testing, TS PC Software**

**Data Management.** The operator can store all measurements and test results on a modern SD memory card up to 32GB, for later visualization in LCD and printing directly from the TS33 using a wireless printer without the need of an external PC and putting the SD card.

**On site testing.** Full automatic test of energy meter can be done **without PC** due to LCD color touch screen and memory for meter types and testing procedures which can be entered manually or imported from PC. This enables to perform testing on site like in laboratory. Results can be saved in memory or printed out by wireless printer.

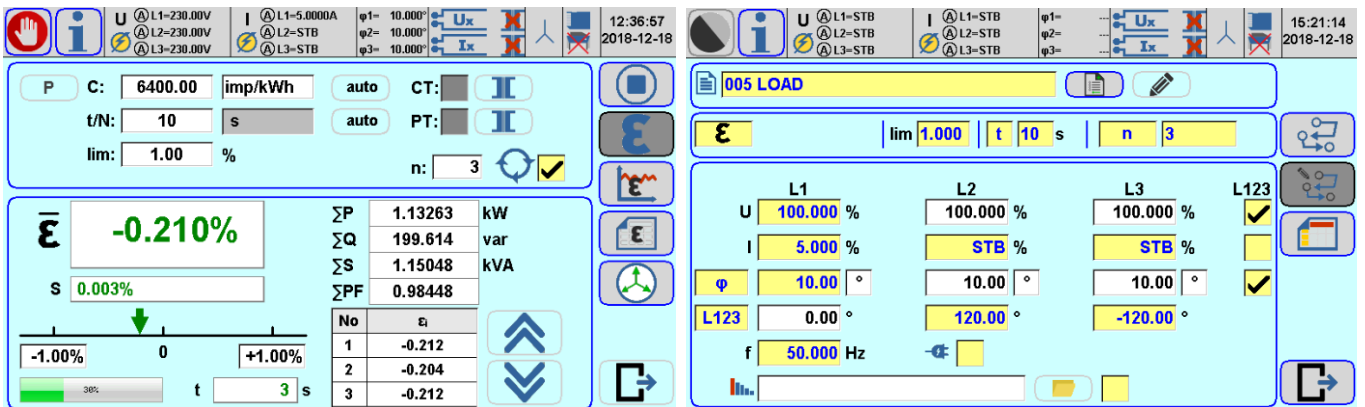

**The TS PC Soft** - data management software provides the ability to transfer the data between TS33 and an external PC. All results can be summarized and printed in a test report by putting the SD card into an external PC or downloaded through USB, Bluetooth or Ethernet. The results can be transferred to Excel

The TS PC Soft software additionally provides the ability to manage data on an external PC or tablet:

- downloading of measurement results from the TS33 to a PC through communication port,
- archiving of measurement results and combining individual results into one collective file,
- printing of measurement results in a test reports,
- export of measurement results to Excel (directly to the XLSX file) and to the Windows clipboard.
- testing devices and performing measurements directly from a PC or tablet,
- sending files and test procedures from the TS33 to a PC and from a PC to the TS33,
- simultaneous testing of a device and performing additional activities in separate program windows:
  - ✓ measurement of network parameters,
  - ✓ registration of trends for all measured network parameters,
  - ✓ measurements of harmonics and histograms (bar chart),
  - ✓ observation of oscilloscopes (waveform) and vector diagram,
  - ✓ creating and modifying automatic meter testing procedures.

**Advantages of TS PC Soft:**

- user-friendly operation,
- demonstration software allows training to be given before delivery of the test system,
- database for meters and test procedures,
- fully-automatic test procedures,
- continuous monitoring of the test,
- generation of harmonics,
- generation of special test signals and waveforms acc. to the IEC 62052-11 and EN 50470-1,2,3,
- tables and graphics for presentation of results,
- operator interface available in several languages,
- customers database for automatic measurements report generation.

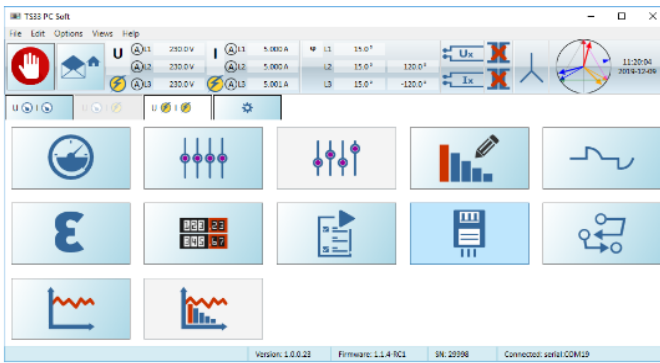

Main menu

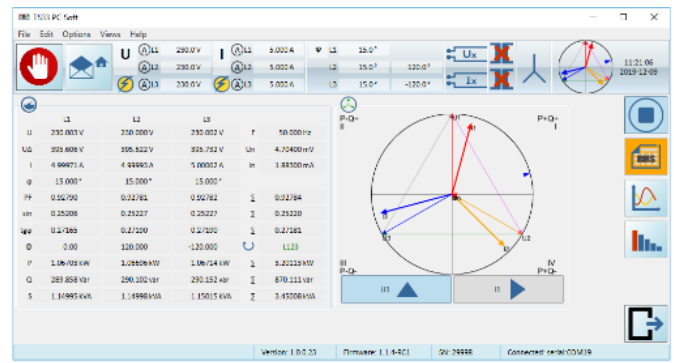

Load point settings

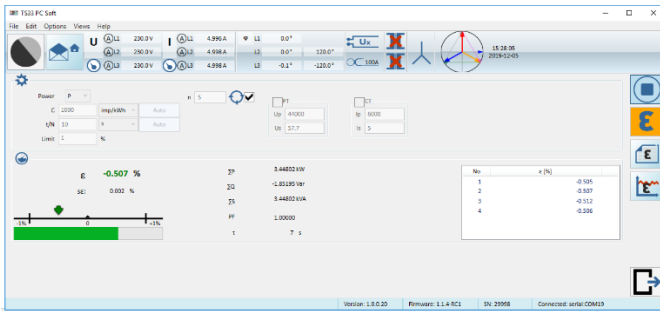

Error test

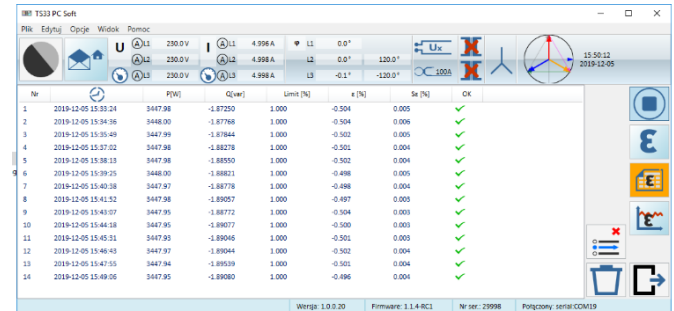

Test results in table form

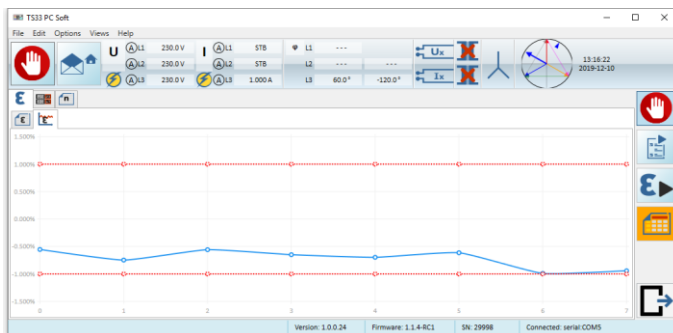

Test results in diagram form

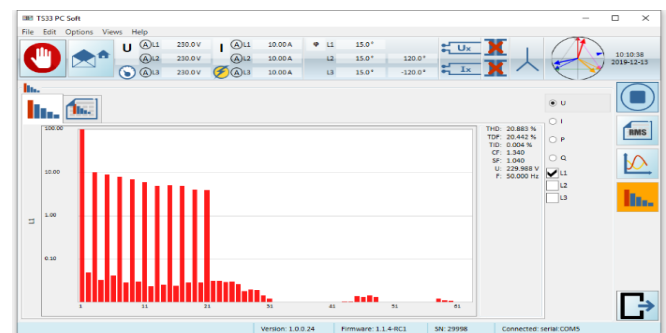

Injected harmonics in voltage

**Calmet TS33 option TB1**

**All completed Calmet TS33 option TB1 single position Test Bench's set consists of:**

- TS33 automatic test system class 0.02, 0.04 or 0.1
- TS PC Soft with USB B / USB A interface cable
- ER10H.3 single position testing stand including:
  - ER10 single position test rack for hanging 3-phase meter,
  - EH10.3 quick connection device (1 unit),
- EA36 - set of safety measurement cables (12pcs)
- EA20 - additional accessories for safety cables
- EA30 - 120A test leads (6pcs) with terminals set (18pcs),
- CF106H photo head for inductive meter and meter with LED (1 unit),
- AD300 sockets adapter,
- C091A T3475-001 plug Amphenol for Calibrator inputs,
- ET30 transportation case for additional accessories,
- memory card SD 8GB,
- fuse T6A 250V (2pcs) and FF16A 500V (6pcs),
- power cord,
- operation manuals and assembly manual,
- warranty card and manufacturer calibration certificate.

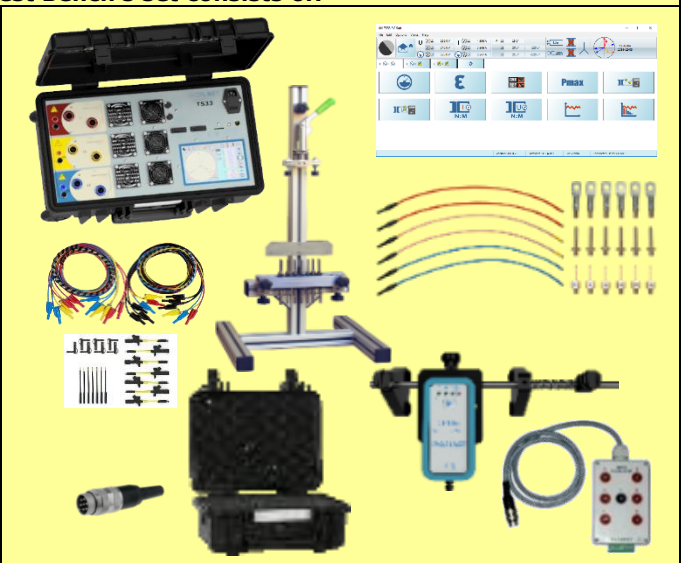

\*) All images are for illustrative purposes only and are subject to change

Calmet sp. z o.o.  
 Kukulcza 18, 65-472 Zielona Gora, Poland  
 Phone +48 68 324 04 56  
 E-mail: mail@calmet.com.pl Web access: http://www.calmet.com.pl